



# Round Sight Glass

PN 16

For welding, according to DIN 28120

**Type  
320**

## Application:

Observation and illumination of the interior of enclosed vessels (cauldrons, tanks, silos etc.).

Sight glasses consist of round flange mountings to be welded into or onto a vessel, completed by a sight glass plate with appropriate seals.

**DIN 28120**  
Operating pressure up to  
16 bar

## Operating conditions:

Temperature:	150 °C
(depending on glass)	280 °C
pressure:	16 Bar

## Materials:

flange:	1.4571, 1.4541, 1.4404, 1.4539, H II
glass:	Borosilicate glass DIN 7080 Soda lime glass DIN 8902
seal:	C4400 PTFE Graphite Or according to spec.
screws:	A4-70

Other materials on request

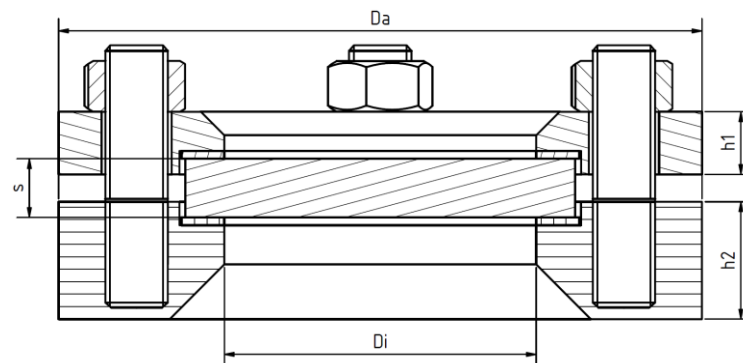

DN	25	40	50	80	100	125	150	200
Da	115	150	165	200	220	250	285	340
Di	48	65	80	100	125	150	175	225
h1	16	16	16	20	22	25	30	35
h2	25	30	30	30	30	30	36	36
s	10	12	15	20	25	25	30	30
Kg	2,9	5,1	6,0	10,3	11,5	15,2	23,5	30,7



## Installation guideline:

After welding the base flange onto/into the pressure vessel, the sealing surface must be checked for deformations! Reworking may be required!

The operating pressure does not apply to the base flange. The base flange must be audited together with the pressure vessel according to AD 2000 instructions B9 or an equivalent standard!

Technical changes and errors reserved!



# Round Sight Glass

PN 16

For welding, according to DIN 28120

**Type  
320**

Product code:

		DN	flange	Glass	Seal	Variants
11	320	Entspr. Tabelle	1: 1.4571 / 1.4541 2: 1.4571 / 1.4571 3: 1.4404 / 1.4541 4: 1.4404 / 1.4404 5: 1.4404 / 1.4571 6: 1.4306 / 1.4306 7: P265GH / S235JR+N 8: other materials (e.g. Hastelloy) on request	1: BS Transparent 2: SL Transparent 3: Quartz 4: BS + PTFE Wiper 5: BS + Sil. Wiper	1: PTFE 2: FKM 3: NBR 4: C4400 5: Silicone 6: EPDM 7: Graphite 8: Special	Assigned by ACI as required.

## Options

- a) Wiper
- b) Spray Nozzle
- c) Double layered glass
- d) Double layered glass and heating element
- e) LED Lights
- f) Protective cover, Type B according to DIN 28120
- g) O Ring Seal (vacuum capable)
- h) Additional options on request

Example:                      **ACI Type 320**  
                                    DN100  
                                    Flange 1.4571 / 1.4541                      11-320-100-1-1-1-000  
                                    Borosilicate glass  
                                    Seal PTFE  
                                    Standard Construction

## Recommendation:

For corrosive media or steam we recommend adding a mica disk to protect the glass.

Technical changes and errors reserved!